



INCOMING KINDERGARTEN SUMMER PROJECT



DIRECTIONS

1. Students will need to read a book and complete the handwriting and math task each week. Do not wait until the end of summer!
2. For the reading task, students may choose any book from the list below or use the book that is recommended for each week.
3. **Summer projects are a graded assignment and are due on the first day of school.**
4. Students who turn projects in at Back to School Orientation will earn a dress down pass!
5. Questions about the summer projects can be directed to Jessica Schott (jschott@rivercityscience.org) and Derya Tozoglu (mtozoglu@rivercityscience.org)

BOOK LIST

FULL, FULL, FULL OF LOVE, BY TRISH COOKE
ALL ABOUT MATTER, BY MARI SCHUH
THE LITTLE ENGINE THAT COULD, BY WATTY PIPER
YOU CAN DO IT, SAM, BY AMY HEST
DIG, WAIT, LISTEN, BY APRIL PULLEY SAYRE
BEAR SNORES ON, BY KARMA WILSON
CITY LULLABY, BY MARILYN SINGER
APPLES, BY GAIL GIBBONS
MY FLORIDA ALPHABET, BY ANNIE P. JOHNSON
FEATHERS FOR LUNCH, BY LOIS EHLERT
WISH, BY EMMA DODD
IS YOUR MAMA A LLAMA?, BY DEBORAH GUARINO
WHAT I LIKE ABOUT ME!, BY ALLIA ZOBEL NOLAN
GIRAFFES CAN'T DANCE, BY GILES ANDREAE
ROSIE'S WALK, BY PAT HUTCHINS
ALPHABET CITY, BY STEPHEN T. JOHNSON
ALEXANDER AND THE TERRIBLE, HORRIBLE, NO GOOD, VERY BAD DAY, BY JUDITH VIORST
BEA AT BALLET, BY RACHEL ISADORA
BEAR FEELS SICK, BY KARMA WILSON AND JANE CHAPMAN
BEN'S TRUMPET, BY RACHEL ISADORA
MAKING FRIENDS, BY FRED ROGERS
TODAY I FEEL SILLY AND OTHER MOODS THAT MAKE MY DAY, BY JAMIE LEE CURTIS
DAVID'S DRAWINGS, BY CATHRYN FALWELL



Rubric for ELA Summer Project

Name: _____

	4	3	2	1	Points Earned
Completion	Student completed all written work in packet.	Student completed most of the written work in packet.	Student completed some of the written work in packet.	Student completed a few pages of written work in packet.	
Answer Quality	Student's work is correct.	Student's work is mostly correct.	Student's work is somewhat correct.	Student's work has many incorrect answers.	
Handwriting	Student's handwriting is neat and legible throughout the entire packet.	Student's handwriting is neat and legible throughout most of the packet.	Student's handwriting is neat and legible throughout some of the packet.	Student's handwriting is NOT neat and legible throughout the packet.	
				Total Points:	
				Grade:	



Rubric for Math Summer Project

Name: _____

	4	3	2	1	Points Earned
Completion	Student completed all assigned work in packet.	Student completed most of the assigned work in packet.	Student completed some of the assigned work in packet.	Student completed a few pages of assigned work in packet.	
Accuracy	Student's work is correct.	Student's work is mostly correct.	Student's work is somewhat correct.	Student's work has many incorrect answers.	
Neatness	Project is orderly and incredibly neat, with no smudges or tears. Student's handwriting is legible.	Project is orderly and neat, with a few smudges or tears. Student's handwriting is legible.	Project has several smudges or tears. Student's handwriting is legible throughout some of the packet.	Project is disorderly, with many smudges or tears. Student's handwriting is NOT legible throughout the packet.	
				Total Points:	
				Grade:	



Kindergarten Grade Summer Project Weekly Calendar



SUBJECT

WEEK 1
JUNE 1-5

WEEK 2
JUNE 8-12

WEEK 3
JUNE 15-19

WEEK 4
JUNE 22-26

WEEK 5
JUNE 29 - JULY 3

ELA

Recommended Book:
Is your Mama a Llama?, by Deborah Guarino
Handwriting: pages 7-9

Recommended Book:
Making Friends, by Fred Rogers
Handwriting: pages 10-12

Recommended Book:
All About Matter, by Mari Schuh
Handwriting: pages 13-15

Recommended Book:
The Little Engine that Could, by Watty Piper
Handwriting: pages 16-18

Recommended Book:
You Can Do It, Sam, by Amy Hest
Handwriting: pages 19-21

Math

Part 1: The Number 1 (page 91)
Part 2: Counting 1 (page 101)

Part 1: The Number 2 (page 92)
Part 2: Counting 2 (page 102)

Part 1: The Number 3 (page 93)
Part 2: Counting 3 (page 103)

Part 1: The Number 4 (page 94)
Part 2: Counting 4 (page 104)

Part 1: The Number 5 (page 95)
Part 2: Counting 5 (page 105)

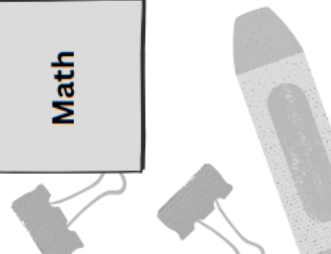



Kindergarten Grade Summer Project Weekly Calendar

SUBJECT	WEEK 6 JULY 6-10	WEEK 7 JULY 13-17	WEEK 8 JULY 20-24	WEEK 9 JULY 27-31	WEEK 10 AUG. 3-7
ELA	Recommended Book: <i>Dig, Wait, Listen</i> , by April Pulley Sayre Handwriting: pages 22-24	Recommended Book: <i>Bear Snores On</i> , by Karma Wilson Handwriting: pages 25-27	Recommended Book: <i>City Lullaby</i> , by Marilyn Singer Handwriting: pages 28-30	Recommended Book: <i>Apples</i> , by Gail Gibbons Handwriting: pages 31-33	Recommended Book: <i>Feathers for Lunch</i> , by Lois Ehlert Handwriting: pages 34-36
Math	Part 1: The Number 6 (page 96) Part 2: Counting 6 (page 106)	Part 1: The Number 7 (page 97) Part 2: Counting 7 (page 107)	Part 1: The Number 8 (page 98) Part 2: Counting 8 (page 108)	Part 1: The Number 9 (page 99) Part 2: Counting 9 (page 109)	Part 1: The Number 10 (page 100) Part 2: Counting 10 (page 110)

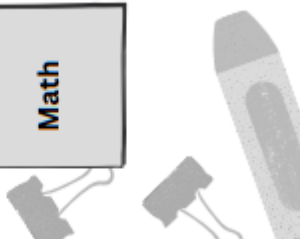

The Number 1

Trace then write each number and number word.

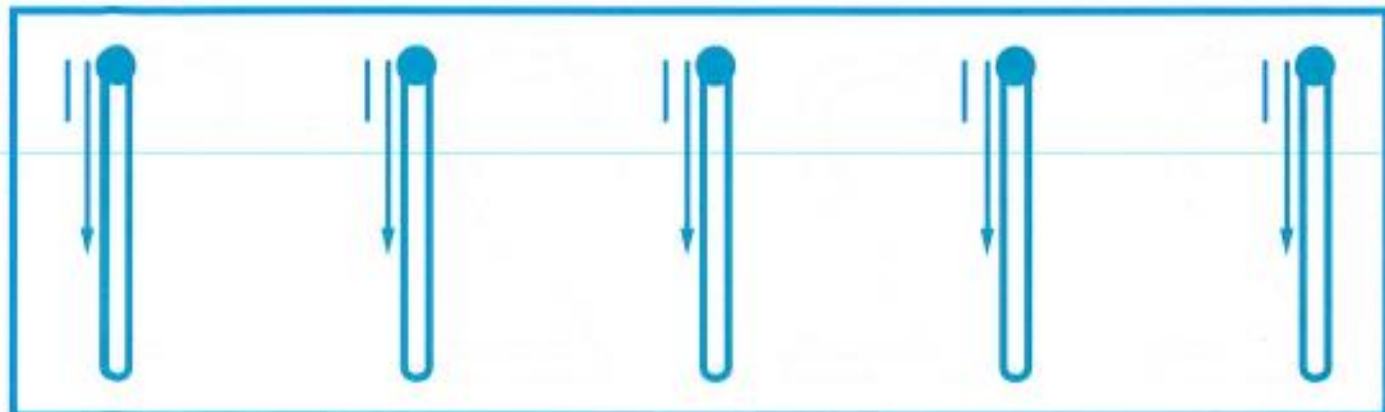

Draw one of your favorite toys!



Counting 1

TRACE the number 1.



WRITE the number 1.

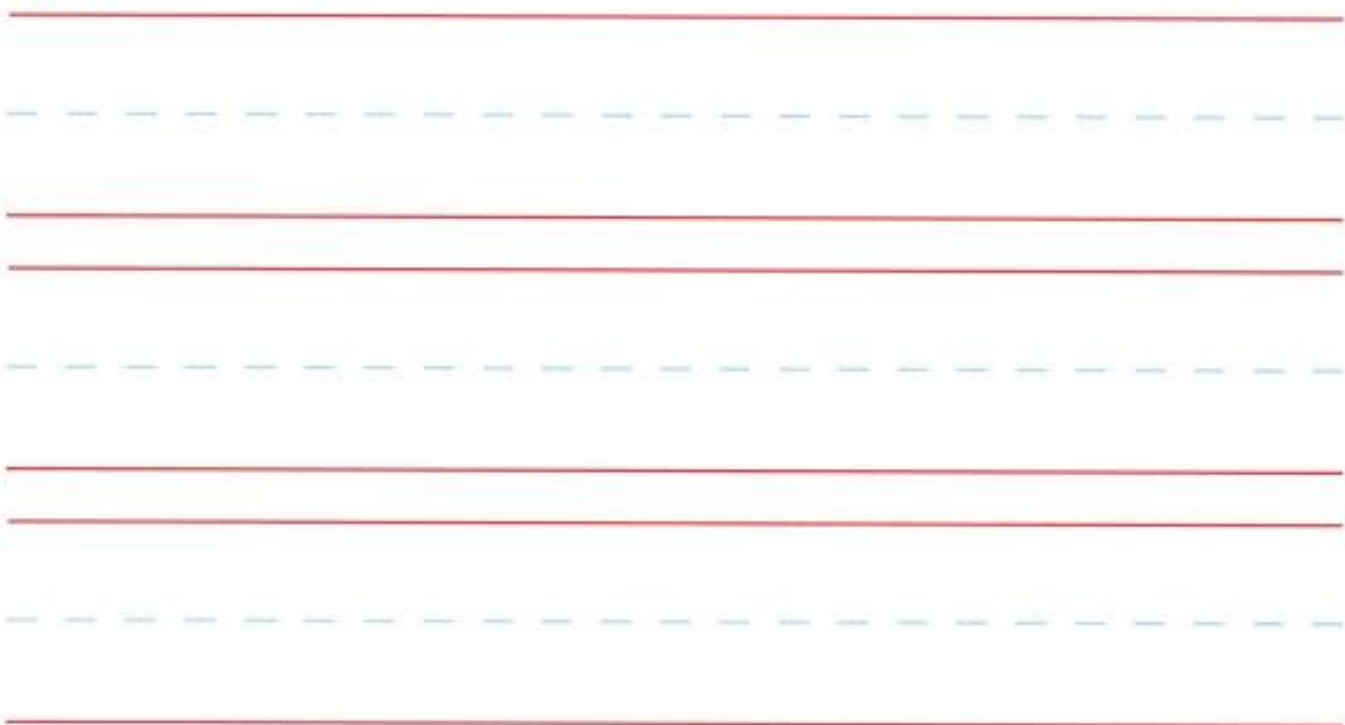

CIRCLE 1 ball.

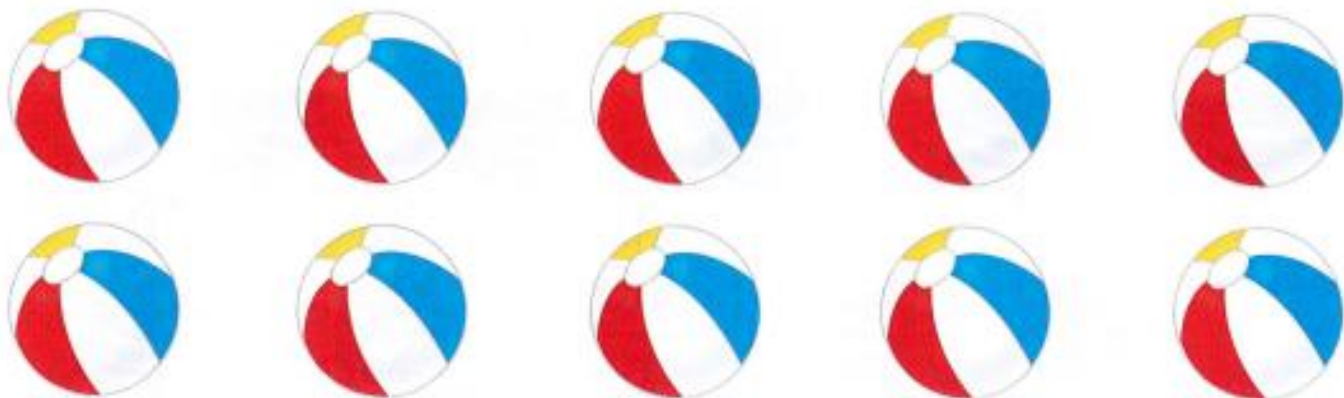

The Number 2

Trace then write each number and number word.

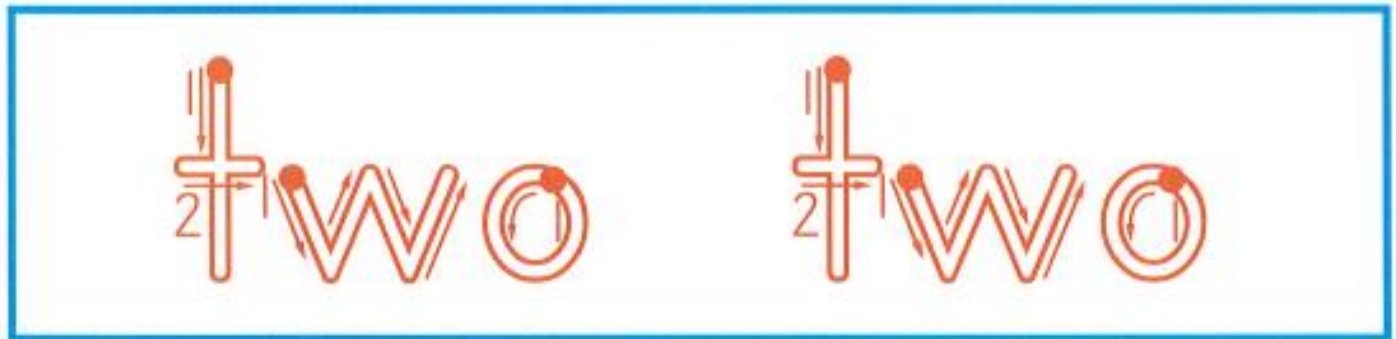

Draw two of your favorite fruits!



Counting 2

TRACE the number 2.



WRITE the number 2.

Three sets of handwriting lines for practicing writing the number 2. Each set consists of a solid top line, a dashed middle line, and a solid bottom line.

CIRCLE 2 bees.



The Number 3

Trace then write each number and number word.



Draw three things you like to play in the summertime!



Counting 3

TRACE the number 3.



WRITE the number 3.

CROSS out 3 apples.



The Number 4

Trace then write each number and number word.



Draw four things you like to play with outside!

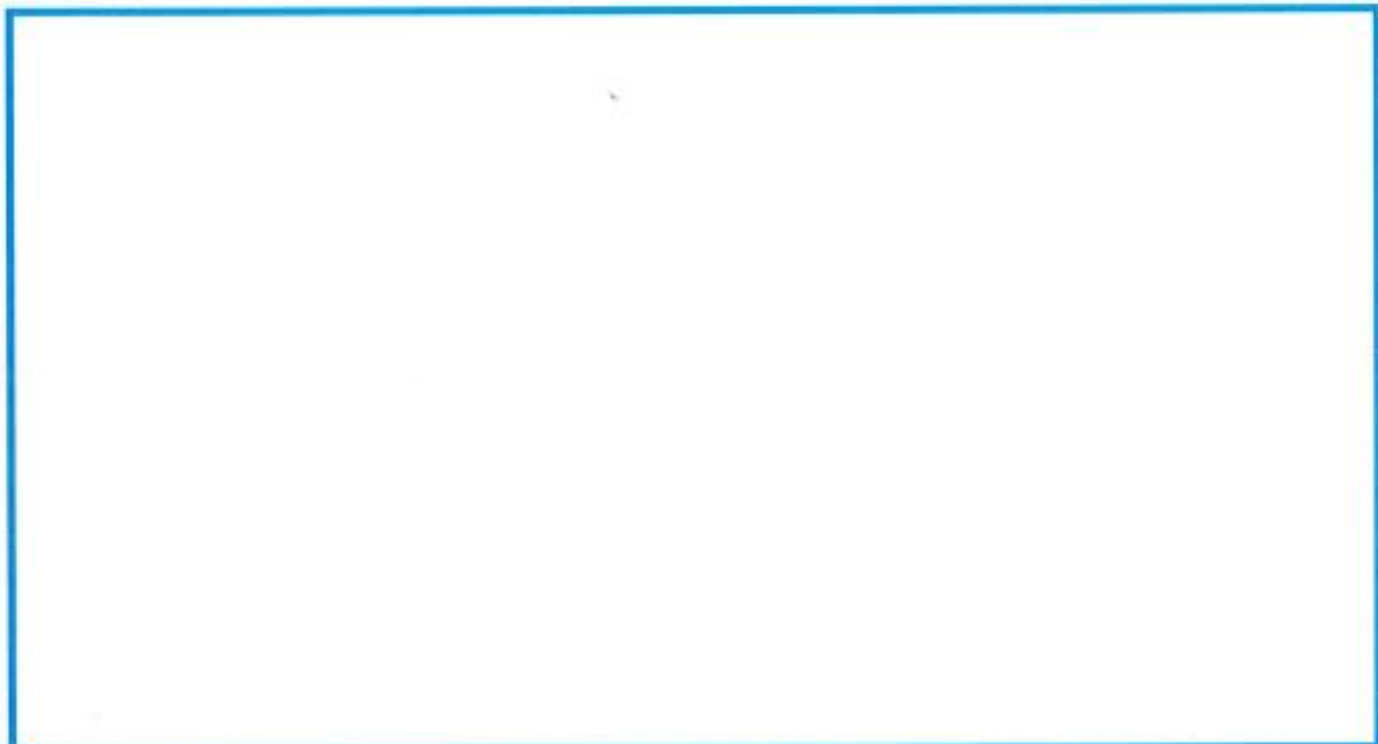

Counting 4

TRACE the number 4.



WRITE the number 4.

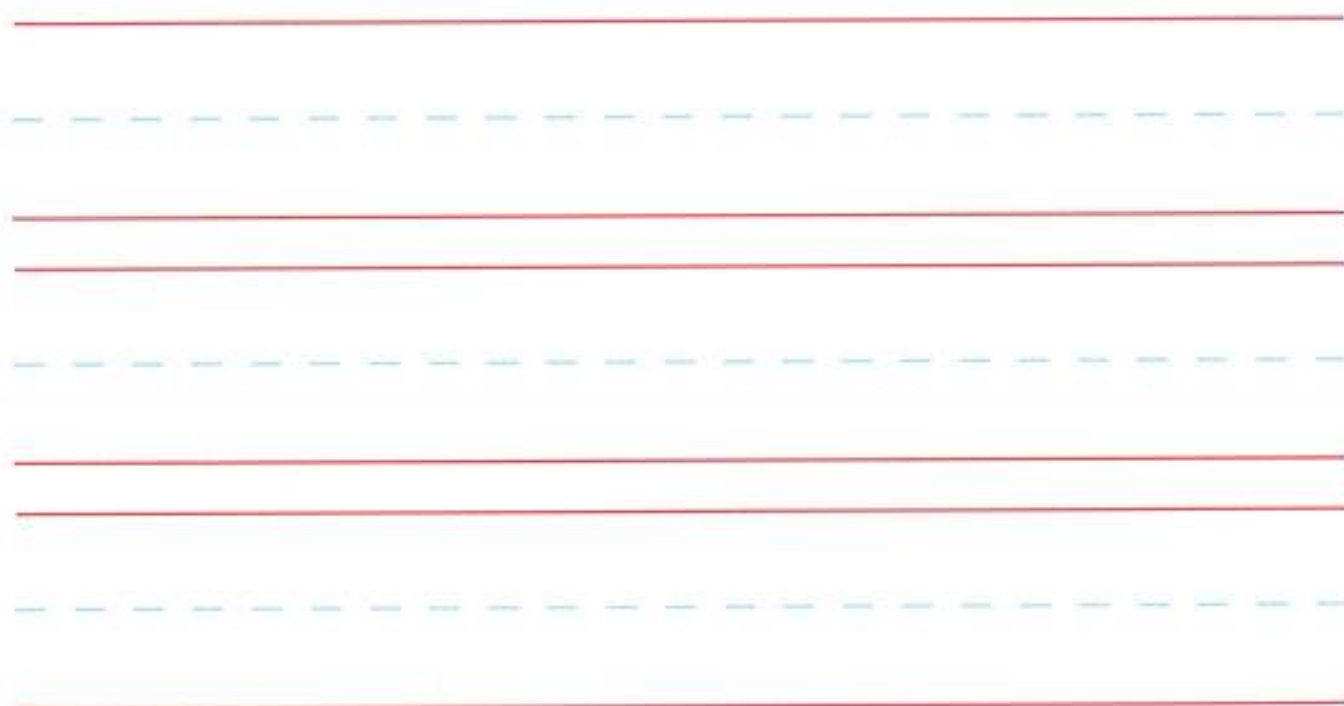

COLOR 4 stars.

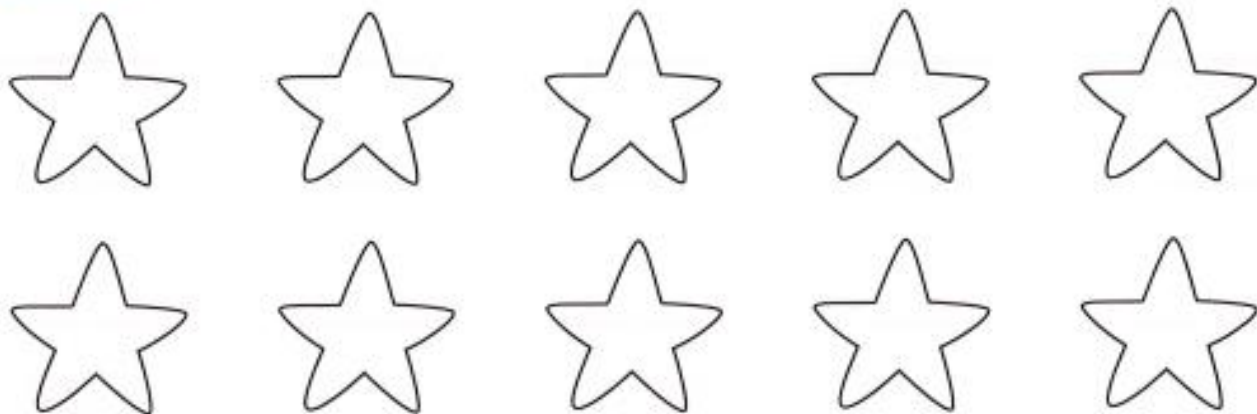

The Number 5

Trace then write each number and number word.

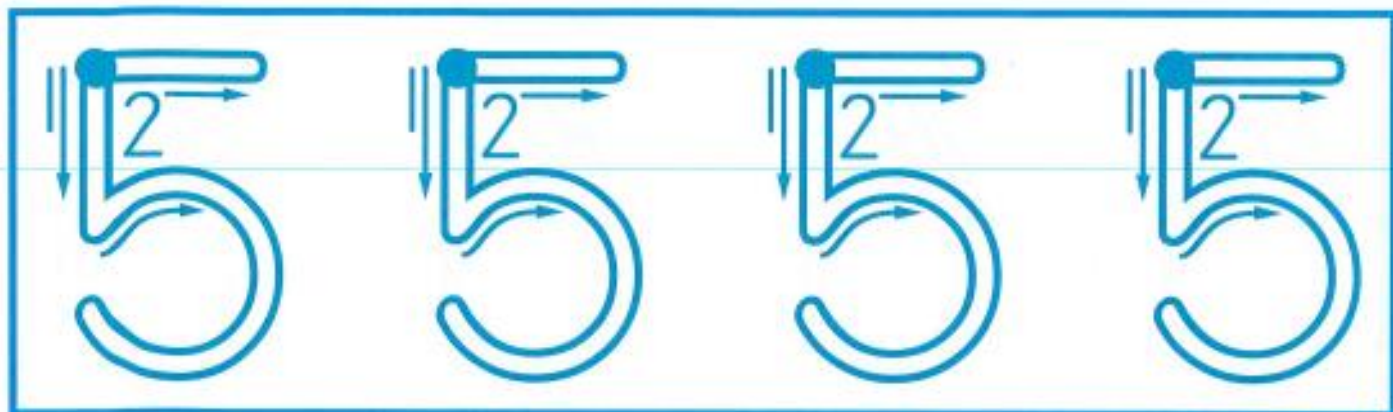

Draw five of your favorite shapes!



Counting 5

TRACE the number 5.



WRITE the number 5.

Two sets of handwriting lines for practicing writing the number 5. Each set consists of a solid top line, a dashed middle line, and a solid bottom line.

CIRCLE 5 flowers.

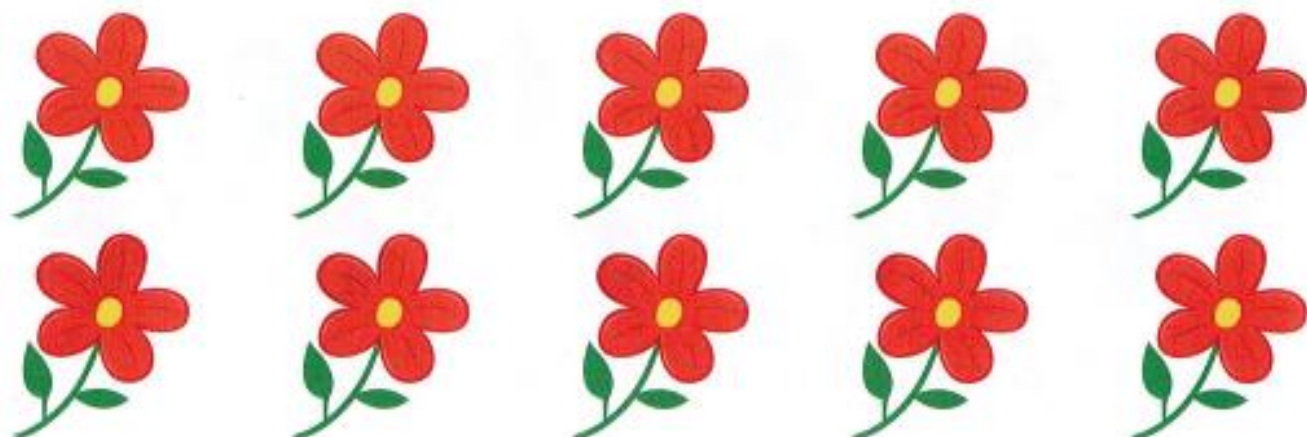

The Number 6

Trace then write each number and number word.

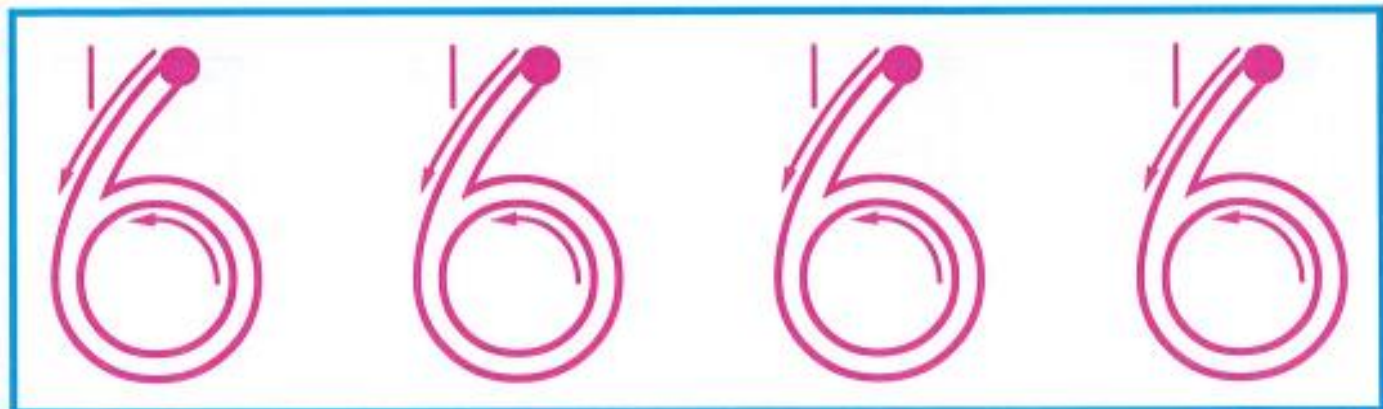

Draw six of your favorite foods!



Counting 6

TRACE the number 6.



WRITE the number 6.

Two sets of handwriting lines (top solid red, middle dashed blue, bottom solid red) for practicing writing the number 6.

CIRCLE 6 kites.

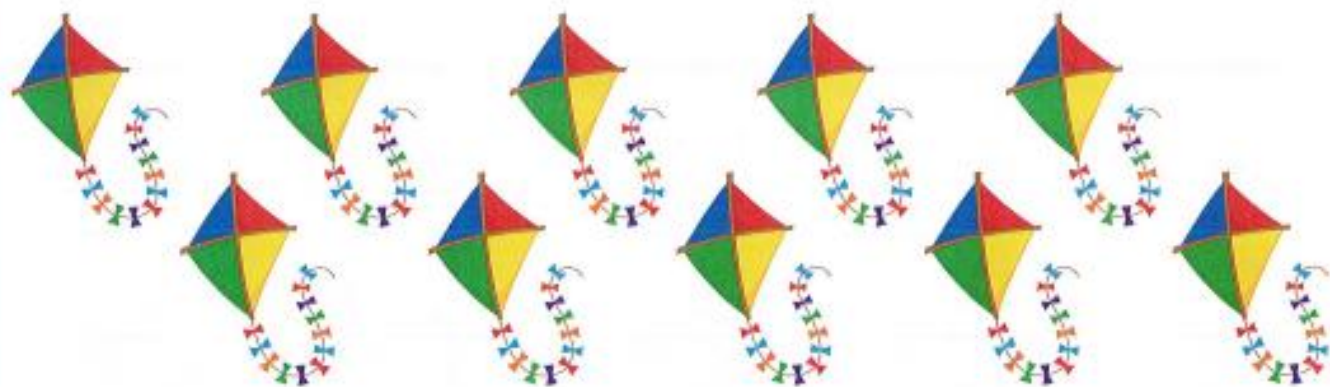

The Number 7

Trace then write each number and number word.



seven seven

Draw seven different animals!



Counting 7

TRACE the number 7.



WRITE the number 7.

Four sets of handwriting lines (top solid red, middle dashed blue, bottom solid red) for practicing writing the number 7.

DRAW a box around 7 ice cream cones.



The Number 8

Trace then write each number and number word.



Draw eight colorful flowers!



Counting 8

TRACE the number 8.



WRITE the number 8.

Two sets of handwriting lines for practicing writing the number 8. Each set consists of a top red line, a middle dashed blue line, and a bottom red line.

CIRCLE 8 ladybugs.

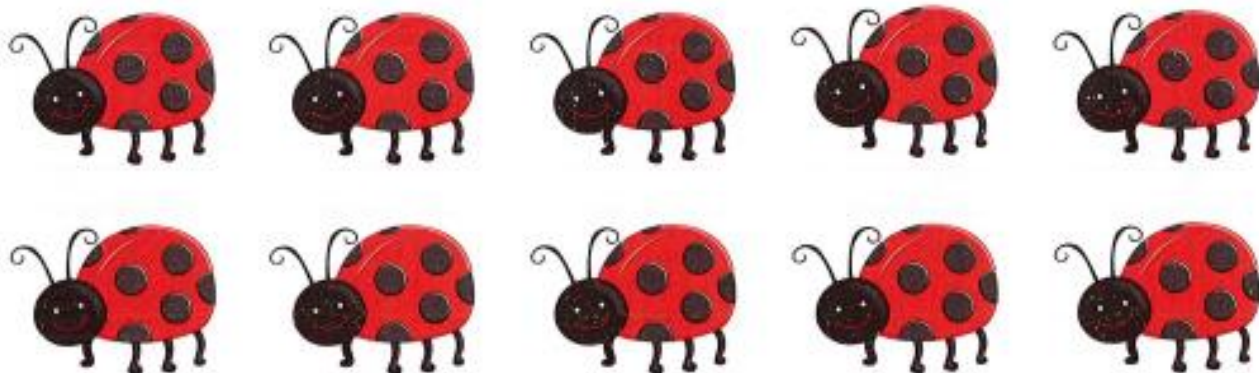

The Number 9

Trace then write each number and number word.

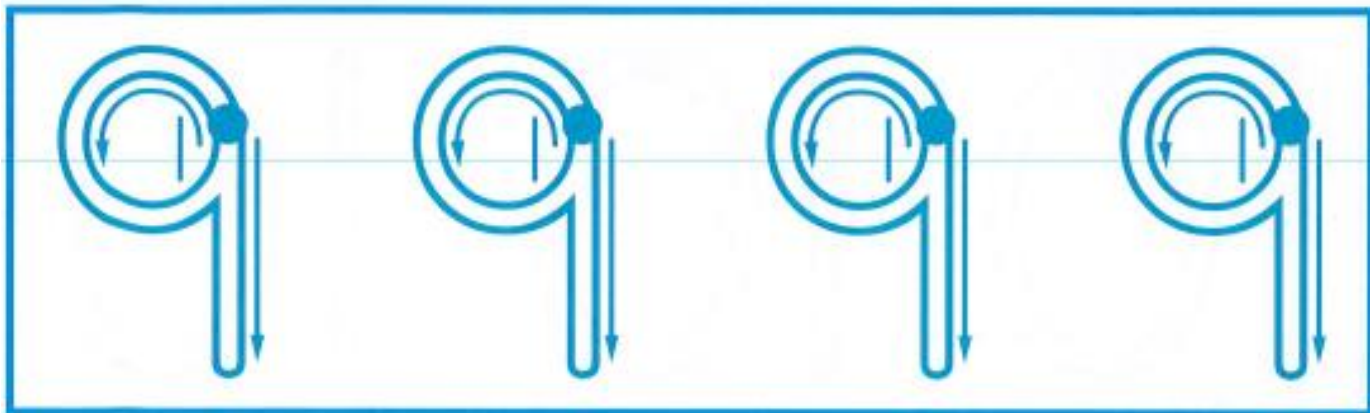

Draw nine make-believe bugs!



Counting 9

TRACE the number 9.



WRITE the number 9.

Two sets of handwriting practice lines. Each set consists of a solid top line, a dashed middle line, and a solid bottom line, providing space for writing the number 9.

CIRCLE 9 dogs.



The Number 10

Trace then write each number and number word.

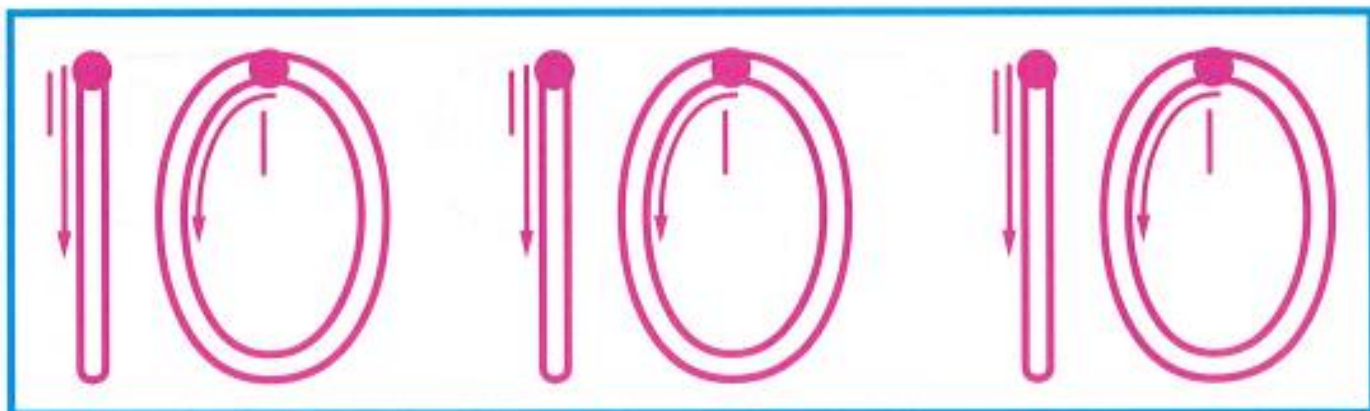

Draw ten things related to sports!

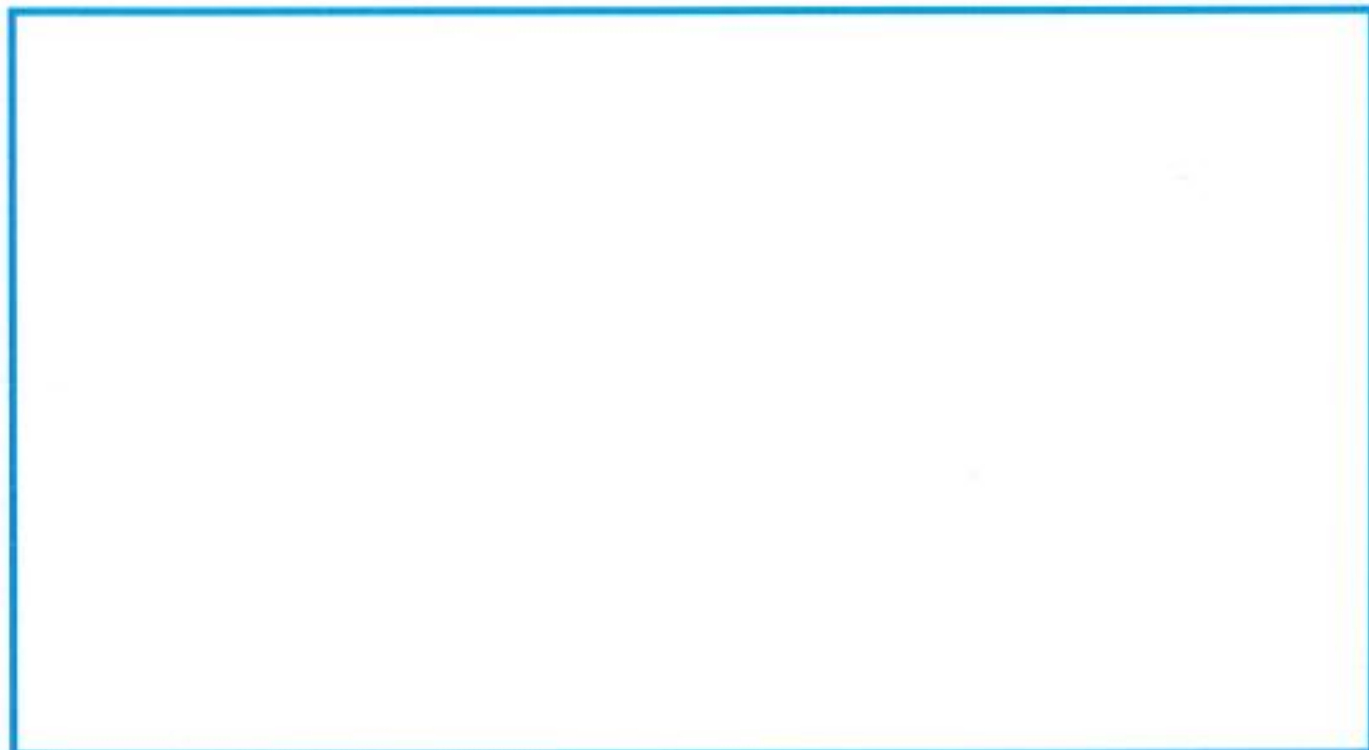

Counting 10

TRACE the number 10.

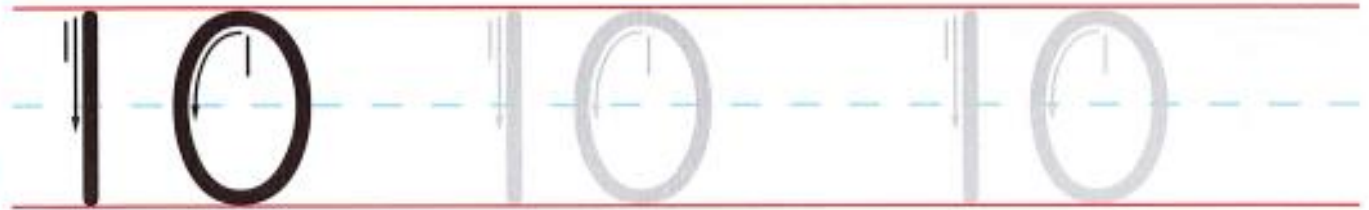

WRITE the number 10.

Two sets of handwriting lines (top and bottom) for practicing writing the number 10. Each set consists of a solid top line, a dashed middle line, and a solid bottom line.

DRAW a box around 10 umbrellas.



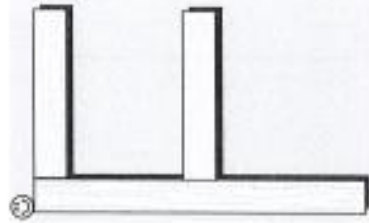
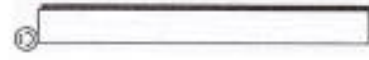
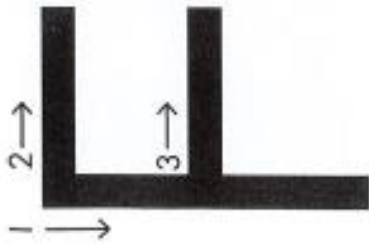

BIG LINE

+ LITTLE LINE

+ LITTLE LINE

Trace F.

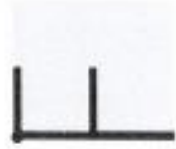

Copy F.

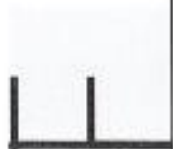

FISH

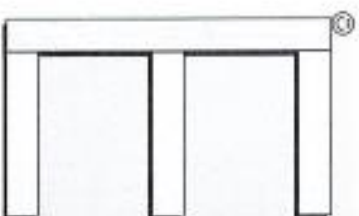
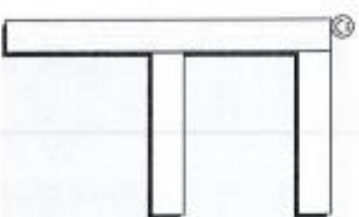
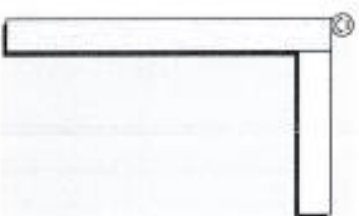
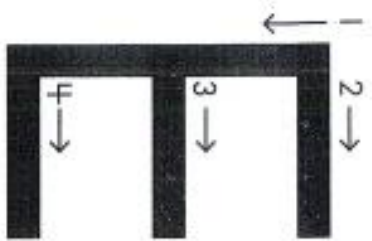

BIG LINE

+ LITTLE LINE

+ LITTLE LINE

+ LITTLE LINE

Trace E.



Copy E.



EAGLE



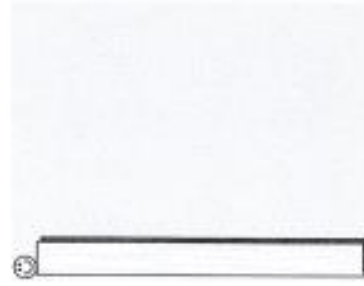
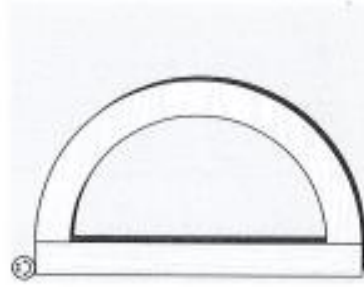
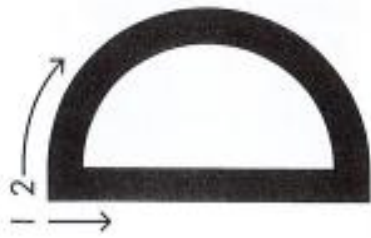

+ BIG CURVE

BIG LINE

Trace **D**.



Copy **D**.



DOLPHIN



BIG LINE

+ LITTLE CURVE

Trace P.

P



P



P



P



Copy P.

P



P



P



P



PIG

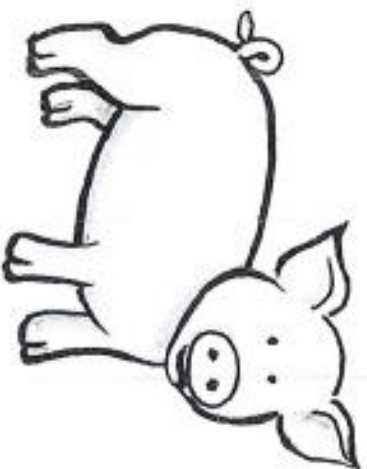



Trace B.

B

Copy B.

B



BIG LINE

B



+ LITTLE CURVE

B



+ LITTLE CURVE

B

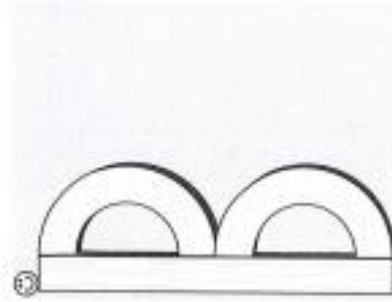

B

B

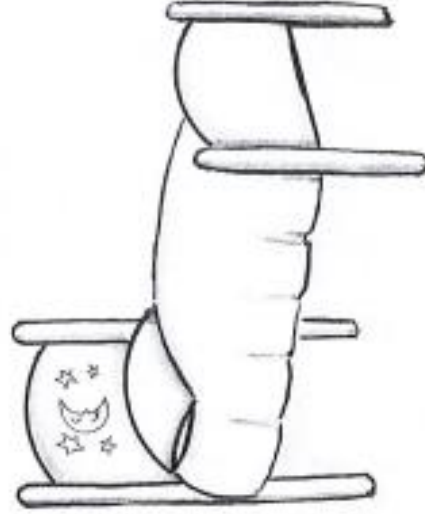

BED



BIG LINE



+ LITTLE CURVE



+ LITTLE LINE

Trace R.



Copy R.

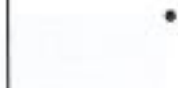

RAINBOW



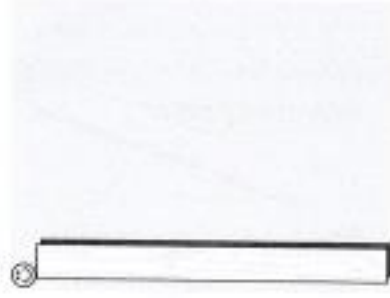
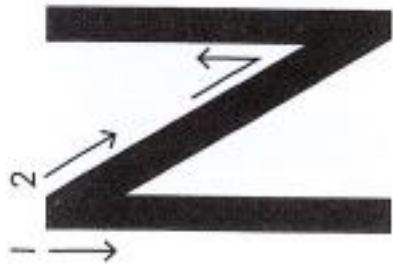

BIG LINE

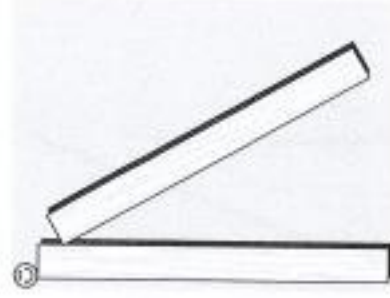

+ BIG LINE

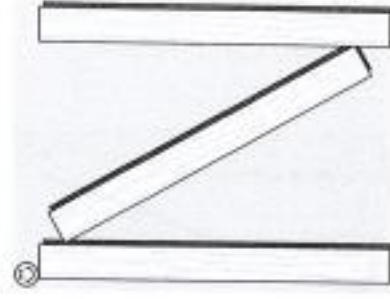

+ BIG LINE

Trace N.



Copy N.

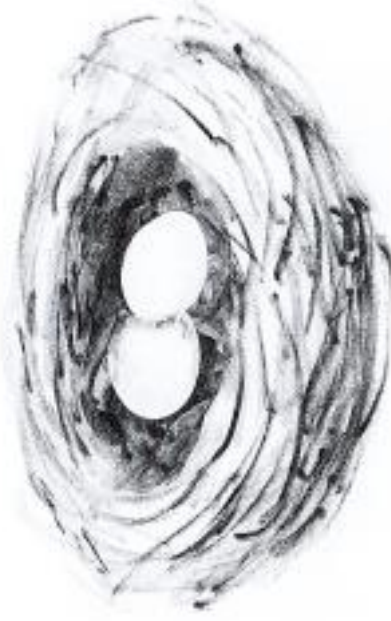

NEST

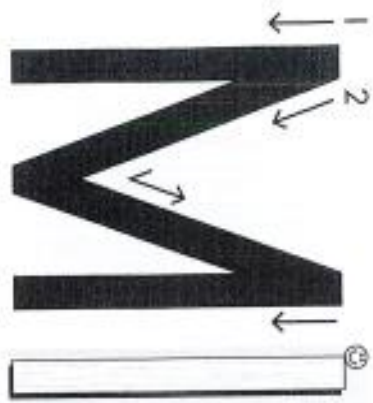

BIG LINE

+ BIG LINE

+ BIG LINE

+ BIG LINE



Trace M.

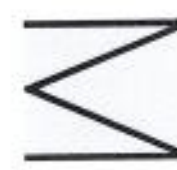
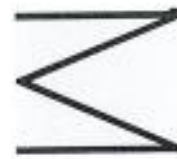

Copy M.



MONKEY

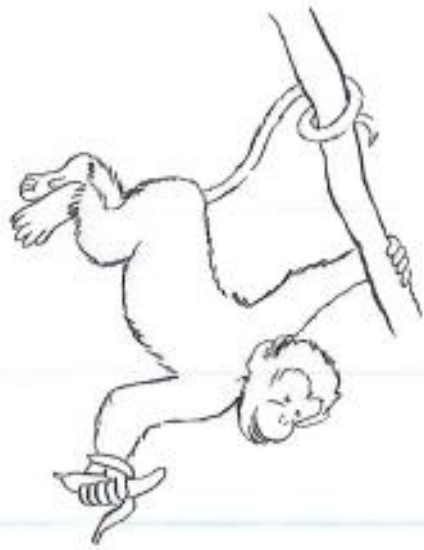

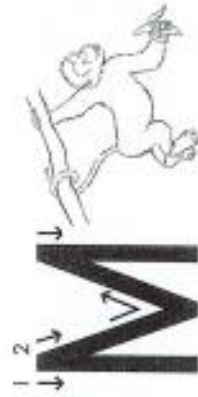
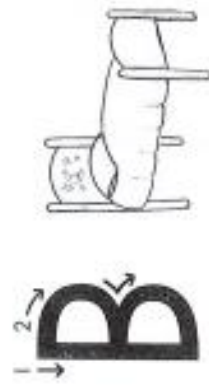

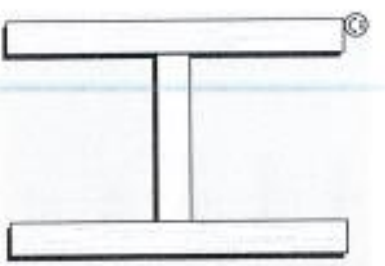
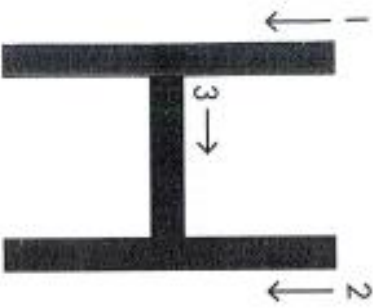

BIG LINE

+ BIG LINE

+ LITTLE LINE

Trace H.



Copy H.

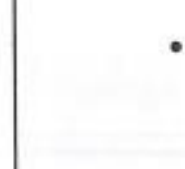

HORSE



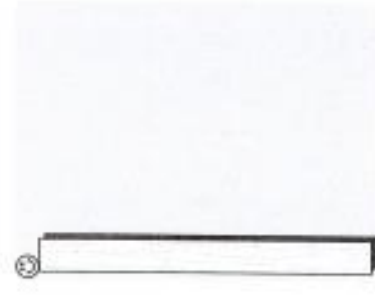
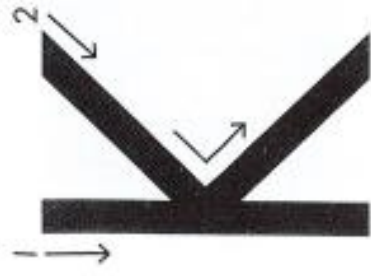

BIG LINE

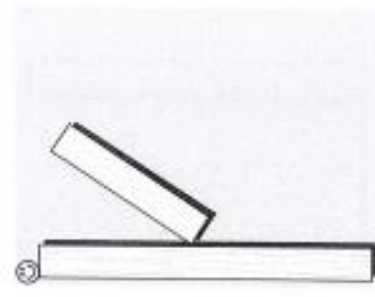

+ LITTLE LINE

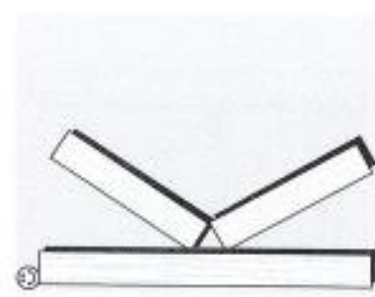

+ LITTLE LINE

Trace K.



Copy K.



KITE





Trace L.

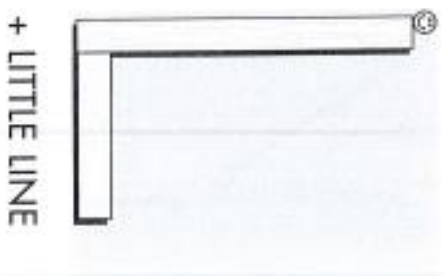
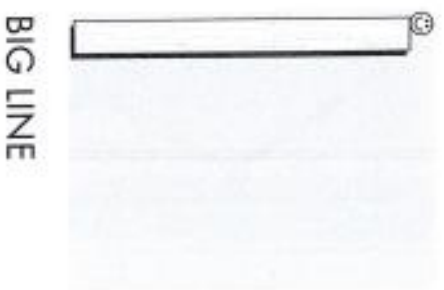

Copy L.



LION



↓
U

Note: We do not use Wood Pieces to teach this letter.

Trace U.



Copy U.



UNICORN





BIG LINE

+ BIG LINE

Trace V.



Copy V.



VOLCANO

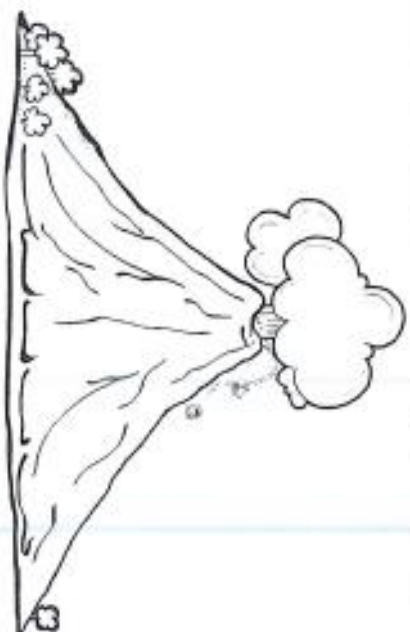

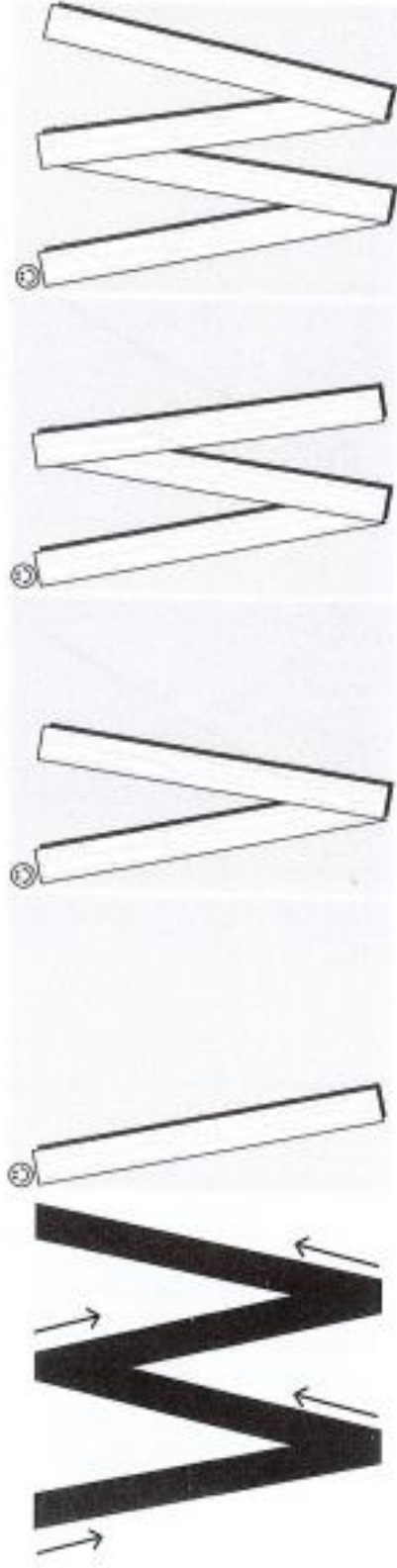

BIG LINE + BIG LINE + BIG LINE + BIG LINE

Trace W.



Copy W.

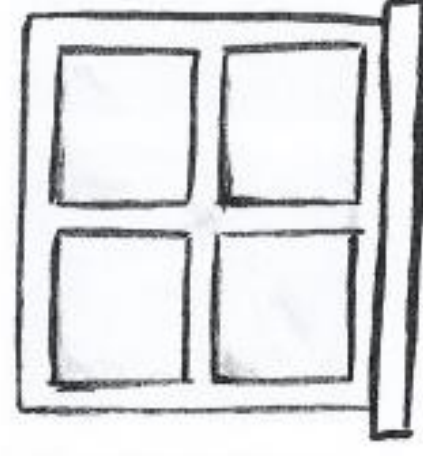

WINDOW

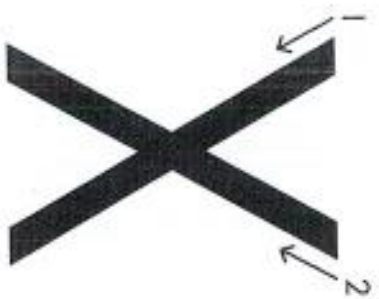

BIG LINE

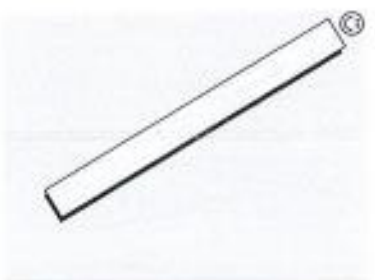

+ BIG LINE

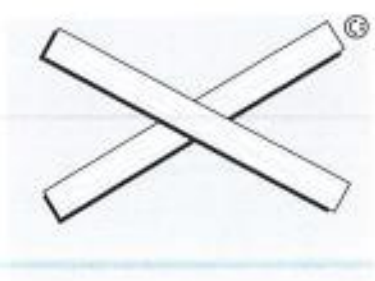

Trace X.



Copy X.

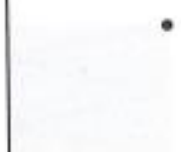

X-RAYS

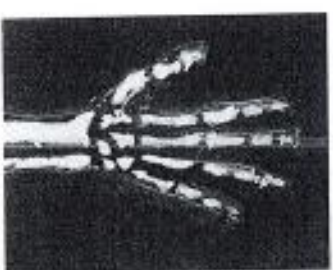

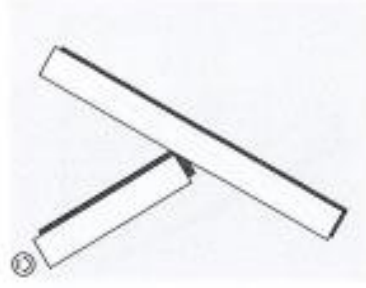
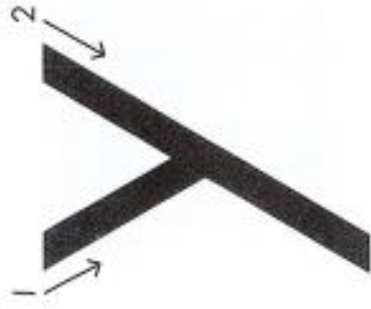

LITTLE LINE

+ BIG LINE

Trace Y.



Copy Y.



YELLOW



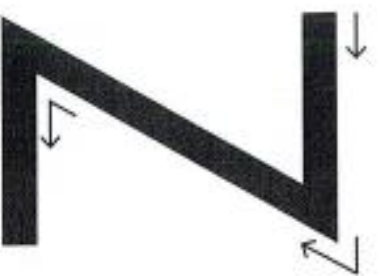

LITTLE LINE

+ BIG LINE

+ LITTLE LINE

Trace Z.



Copy Z.



ZEBRA



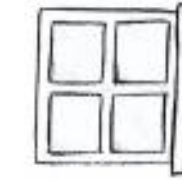

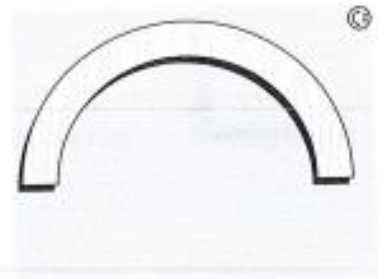

BIG CURVE

Trace C.



Copy C.



CAR



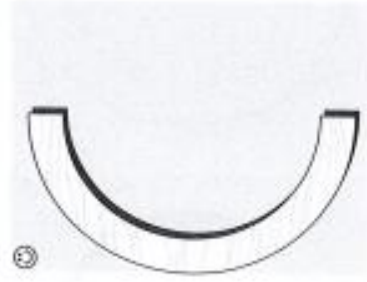

BIG CURVE

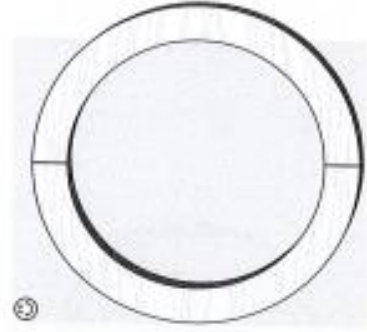

+ BIG CURVE

Trace O.



Copy O.



OCTOPUS

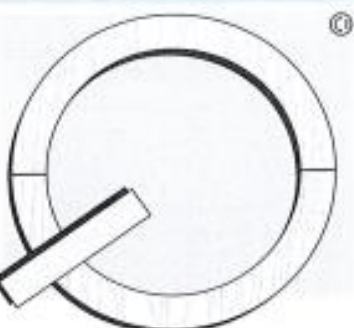
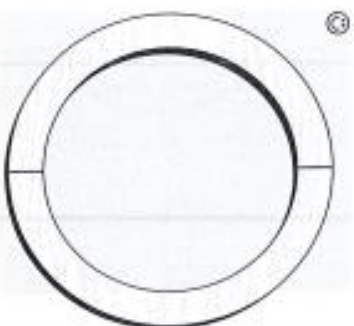
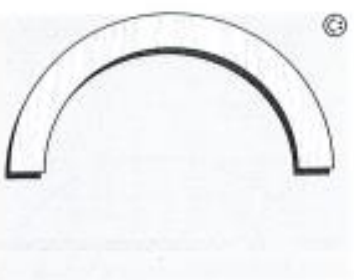
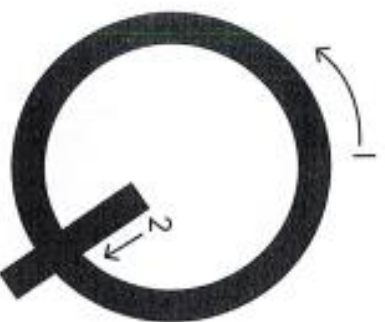

BIG CURVE

+ BIG CURVE

+ LITTLE LINE

Trace Q.



Copy Q.

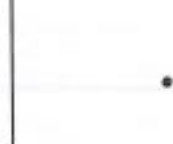

QUEEN

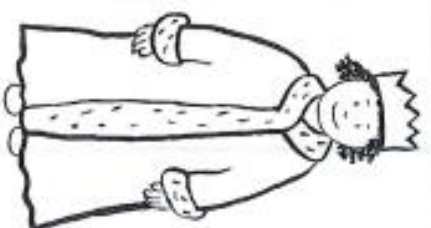

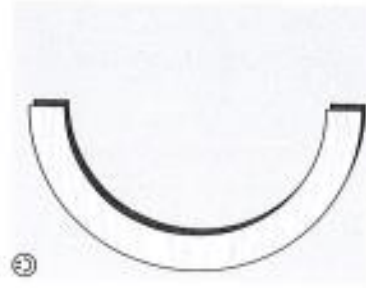
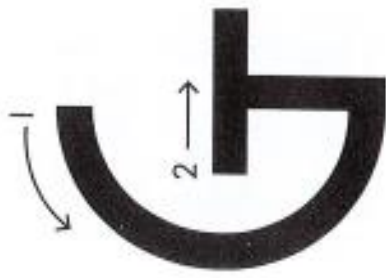

BIG CURVE



+ LITTLE LINE

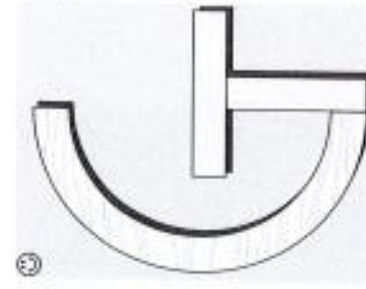

+ LITTLE LINE

Trace G.



Copy G.



GOAT



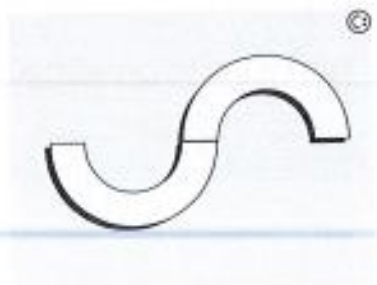

LITTLE CURVE + LITTLE CURVE

Trace S.



Copy S.



SAW

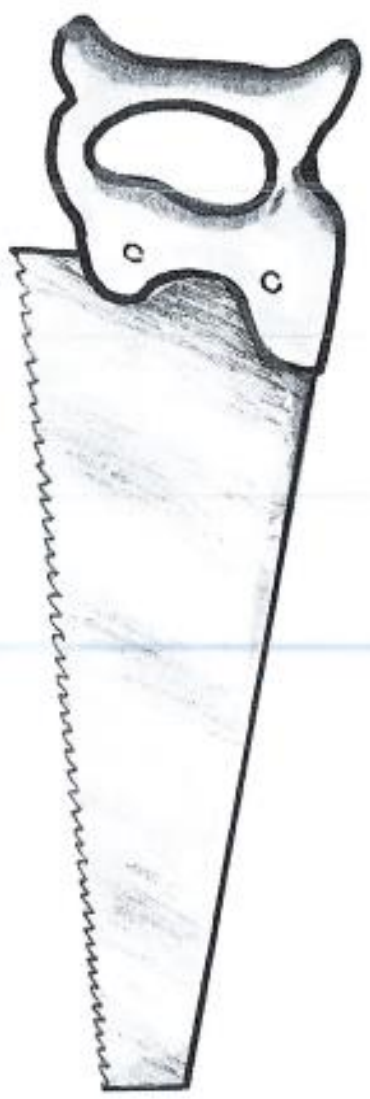

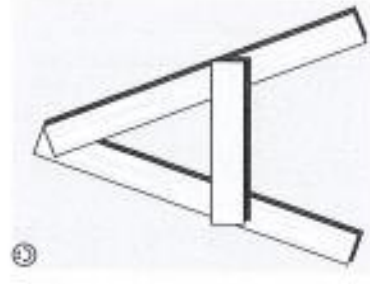
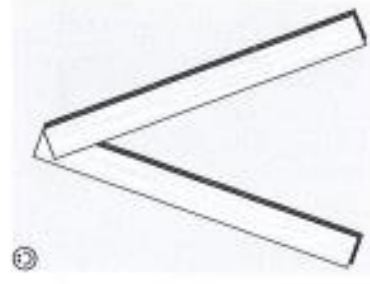
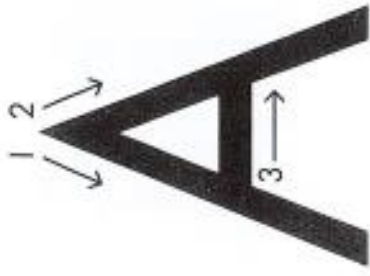

BIG LINE

+ BIG LINE

+ LITTLE LINE

Trace A.

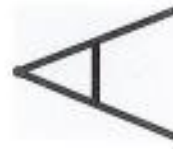

Copy A.

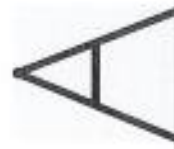

ANT

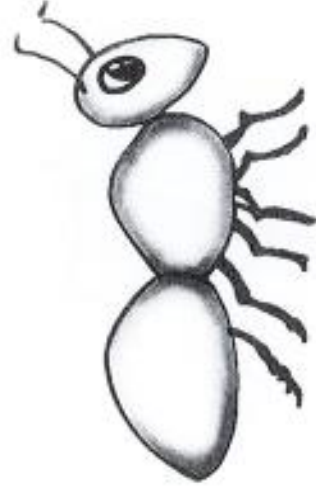



Trace I.



BIG LINE



+ LITTLE LINE

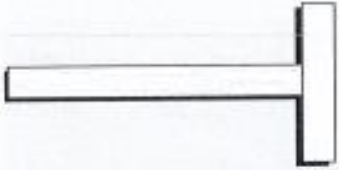

+ LITTLE LINE

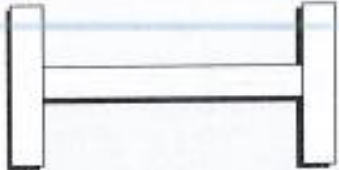

Copy I.

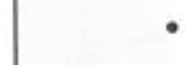

ICE CREAM

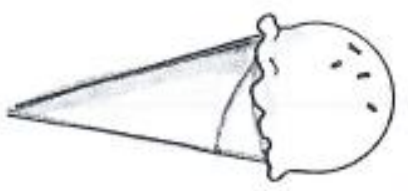

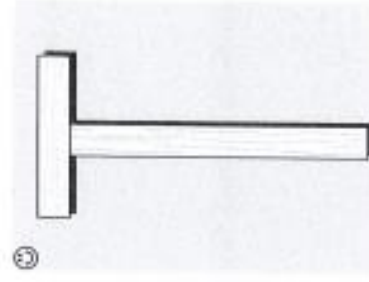
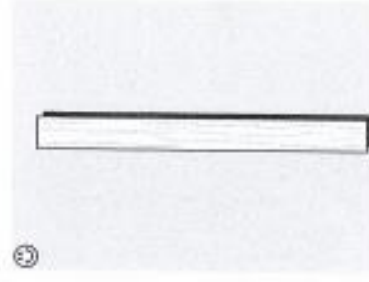

BIG LINE

+ LITTLE LINE

Trace T.



Copy T.



TIGER



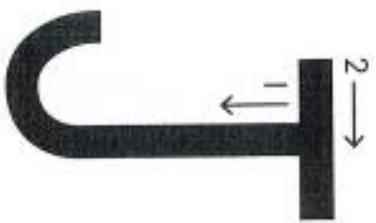

Note: We do not use Wood Pieces to teach this letter.

Trace J.



Copy J.

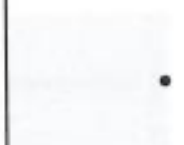

JACKET

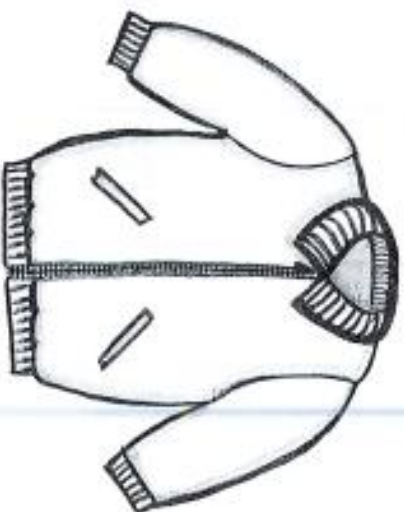

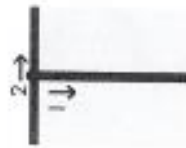
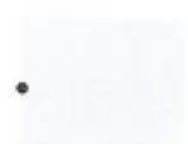
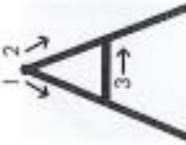
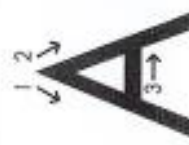
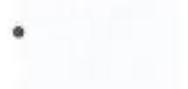
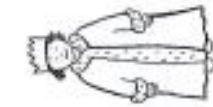

CAPITALS FOR ME

Start on the dot. Trace the capitals.



A

B

C

D

E

F

G

H

A

B

C

D

E

F

G

H

I

J

K

L

M

N

O

P

Q

J

K

L

M

N

O

P

Q

R

S

T

U

V

W

X

Y

Z

R

S

T

U

V

W

X

Y

Z